

**This document is a record of my domestic PV project.**

**Status: Since I first started looking at putting 12kw on my garage roof, the available components and grid services have changed dramatically. Time to update the plan:**

**Darrell Moores**

**Warning - I am not an electrician!!**

### **Aim**

Create a domestic power system that:

- Generates as much solar power as possible.
- Uses as much of that power as possible, stores power if possible and exports excess to the grid.
- Uses the grid to supplement use when load exceeds generation.
- Provides a UPS capability to cover rare grid outages
- Provides EV charge capability to replace existing diesel car for local range travel only
- Provides V2H (Vehicle to Home) and V2G (Vehicle to grid) capabilities
- Makes use of cheap rate electricity and whatever other price models that are developed to integrate small scale generators into a comprehensive grid.
- Reduces current oil used for domestic heating and hot water heating.

### **New System design**

I have 2 grid connections, 1 to a garage building and 1 to the house. I aim to use both supplies because:

- The main fuse to each building is 80Amps.
- House uses a peak of 8kw
- If I plan for 2 electric vehicles charging at 7kw each = 14kw
- Using electricity to run hot water system instead of oil heater uses 3.5kw
- Replacing the oil fired boiler with an electric boiler could use up to 14kw
- Which totals a theoretical peak of 40 kw which at 240V = 166Amps.

Using both grid connections should allow me access to ample grid energy and allows for future proofing.

The current plan is to split the PV into 3 strings, one that is grid tied to the garage supply and 2 that provide DC to off grid inverters for the house (that can pull from the house grid connection, but not export to it).

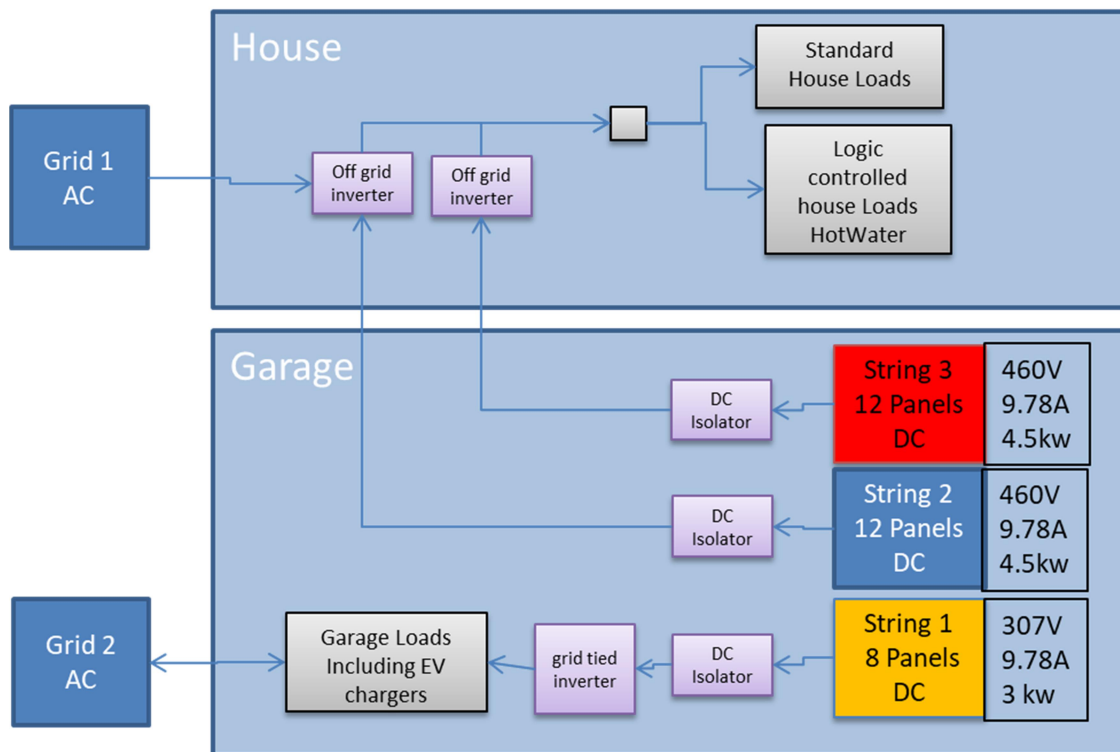

This design allows the house to survive grid power disruptions, (with multiple off grid inverters providing resilience), while the grid tied garage supply can export excess PV to the grid in summer while I am waiting to afford EVs. It also means that I do not have to worry about limiting export power to the grid as I am only connecting 3KW to the export exit, and it gives me a good incentive to make use of my full generation capacity.

When EVs are affordable, I can make use of any EV tariffs that are available, and also allow the power companies to make use of my EV battery storage to balance grid supplies in V2G format.

V2H however need some further thought and I have pushed this requirement out to the future as it will require a connection from the EV to the house off grid inverters.

What is left for the Raspberry Pi? Not a lot. No longer need to turn strings on and off to limit export. And Off grid hybrid inverters can now control battery charge and discharge. I could still use the Pi to record load and grid usage (import and export), and to control heating, but that is about it. Is it necessary – probably not less it is used to enable V2H by switching DC inputs to the house inverters.

## Progress

### Planning

Permission was approved in 2019, but relapses after 3 years.

So November 2022 I put 32 UKSol 375w solar panels on my roof, which are not yet connected to AC.

## Panels and mounting

UKSol are a British company manufacturing panels in Europe using Chinese and Indian parts (cells, electrics etc). Because the garage is a single SW facing sloping surface, I used 375w panels without optimisers. The mounting system used was a railless RenuSol metasole+ system for corrugated metal roofs. Installation went smoothly, although it took a long time and scaffolding was essential. I was initially worried about putting 160 screws through my nice water tight metal roof but the mounting system seemed well designed to keep out water. Using clips to manage the connecting wires between the panels is also essential to keep the wires from rubbing against the roof. I used 6mm Solar wire with MC4 connectors to connect the strings to the DC isolators, and put all DC wiring inside the roof into flexible conduit as we sometimes get critters in the roof space, and this just gives extra protection against those desperate enough to chomp on insulation.

## Grid tied connection

In the UK the FITS incentive payments have been withdrawn, but the power suppliers are now able to offer to buy excess energy under the Smart Export Guarantee (SEG) process. This does however require a smart meter, so the power companies can correctly measure exported and imported power (instead of just reversing the meter during export). The power companies also require a MCS certificate and a G99 or G98 self generation certificate. V2G can now be managed by industry standard EV chargers which the power companies can control with some input from EV owners.

Which means you cannot just put the panels up yourself and get an electrician to plumb in an inverter.

MCS certificate can only be provided by an MCS registered installer.

G99/G98 certificate can only be supplied by the local distribution network operator (DNO), and they require an MCS certificate.

Smart meters can be supplied by the DNO or the power supplier, and as I need to rewire the garage building to get all the wiring onto a single board so that I can put on a control system, I am looking first at replacing the meter and at the same time installing the main fuse in the external meter box.

## Fire risk

One of the concerns of neighbours is fire risk. Providing an easy way for firefighters to disconnect the system seems like a useful thing to do to ease neighbourly tensions. An external main fuse and switch would provide easy AC isolation, which in turn would turn off the grid tied inverter and isolate the garage loads. The DC panels however are a problem, as whatever you do, they will still generate power in daylight or any bright lamps. Providing external access to the DC isolators does not add value, especially as the cause of PV related fires mainly start on the roof due to wire insulation failures and various combustible debris (back to critters and their nests). A metal roof, metal mountings, double insulated wiring, CT4 connections and conduit at the roof exit points all reduce risk, but they do not completely remove it. Inspection of wiring and cleaning of debris will have to form part of a maintenance schedule.

## Next up

Rewiring the garage building ready for an inverter

Laying DC wires from the garage to the house. This is roughly an 80m stretch and will require a short trench across open ground, up a wall into the roof space and then across the house roof space to come down to the consumer units.